

Kompensatory do kompensacji wydłużeń DN20÷350

z przyłączami kołnierzowymi i dwiema osłonami

Dane techniczne

- Ciśnienie pracy – do 2,5 MPa (wg tabeli)
- Temperatura pracy – 150°C – dopuszcza się stosowanie do wyższych temperatur z zastosowaniem odpowiednich współczynników korekcyjnych.
- Kompensacja – według tabeli.

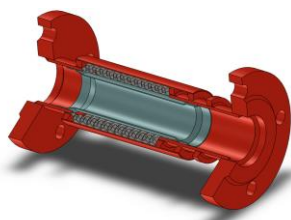

DN20-65 Kołnierze płaskie

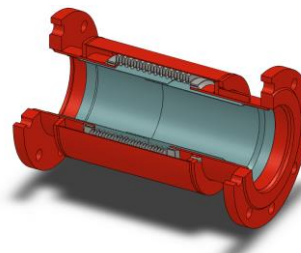

DN80-350 kołnierze płaskie

Materiały

- Mieszki wykonane jako konstrukcja wielowarstwowa ze stali odpornej na korozję 1.4541 lub 1.4301 wg PN-EN10088-2
- Osłony wewnętrzne wykonane ze stali odpornej na korozję 1.4301 wg PN-EN10088-2
- Przyłącza wykonane z kołnierzy stalowych stali P235GH, P245GH, P250GH, P265GH, 1.4301, 1.4541 wg PN-EN 1092-1:2007
- Osłony zewnętrzne wykonana ze stali odpornej na korozję 1.4301 wg PN-EN10088-2 lub P235TR2 wg PN-EN 10216-1:2004/A1:2004

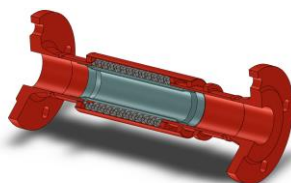

DN20-65 Kołnierze sztykowe

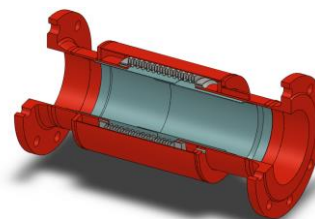

DN80-350 kołnierze sztykowe

Przeznaczenie

- Redukcja naprężeń.
- Kompensacja wydłużeń cieplnych oraz drgań.

Zastosowanie

- Rurociągi ciepłownicze, technologiczne, spalin, wody pitnej.
- Przemysł energetyczny, metalurgiczny, spożywczy, chemiczny etc.
- Czynniki grupy 1 i 2 według 2014/68/UE
- Rurociągi izolowane.



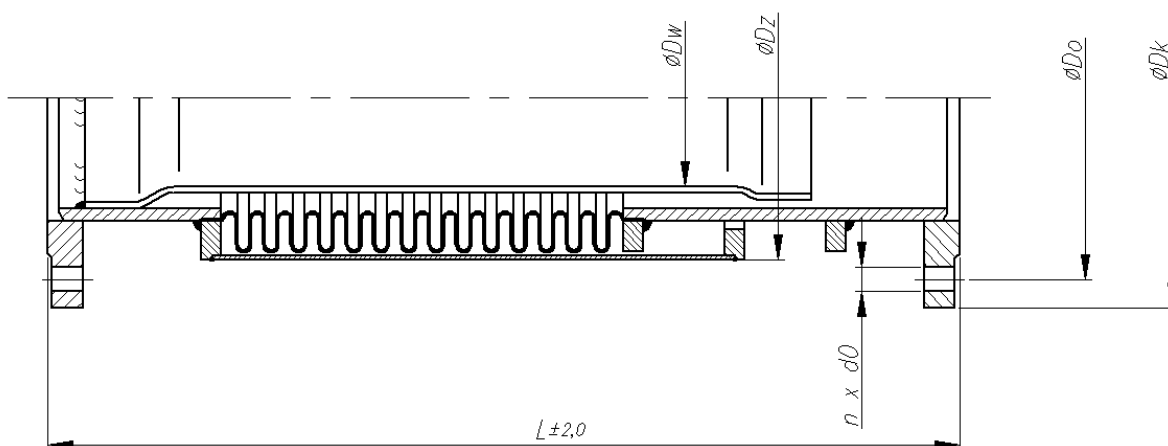

DN	PN	Oznaczenie	Kompensator			Kołnierz				Powierzchnia czynna cm ²	Kompensacja mm	Szttywność N/mm	Ciśnienie	
			L	D _c	D _w	D _k	D _o	d _o	n				pracy	próbne
			mm	mm	mm	mm	mm	mm	szt				MPa	MPa
20	6	KFP20-6s	185	36,5	19,5	90	65	12	4	5,7	16=(±8)	16	0,6	0,9
	10	KFP20-10s				105	75	14				1,0	1,5	
	16	KFP20-16s				105	75	14				1,6	2,4	
25	6	KFP25-6s	200	44,5	25,0	100	75	12	4	9,2	22=(±11)	12	0,6	0,9
	10	KFP25-10s				115	85	14				1,0	1,5	
	16	KFP25-16s				115	85	14				1,6	2,4	
32	6	KFP32-6s	240	57,0	32,0	120	90	14	4	16,0	50=(±25)	12	0,6	0,9
	10	KFP32-10s				140	100	18				1,0	1,5	
	16	KFP32-16s				140	100	18				1,6	2,4	
40	6	KFP40-6s	240	64,0	40,0	130	100	14	4	21,0	50=(±25)	12	0,6	0,9
	10	KFP40-10s				150	110	18				1,0	1,5	
	16	KFP40-16s				150	110	18				1,6	2,4	
50	6	KFP50-6s	240	80,0	50,0	140	110	14	4	34,0	50=(±25)	52	0,6	0,9
	10	KFP50-10s				165	125	18				1,0	1,5	
	16	KFP50-16s				165	125	18				1,6	2,4	
	25	KFP50-25s				255	125	18				2,5	3,2	
65	6	KFP65-6s	240	93,0	65,0	160	130	14	4	48,0	50=(±25)	45	0,6	0,9
	10	KFP65-10s				185	145	18				1,0	1,5	
	16	KFP65-16s				185	145	18				1,6	2,4	
	25	KFP65-25s				255	145	18				2,5	3,2	



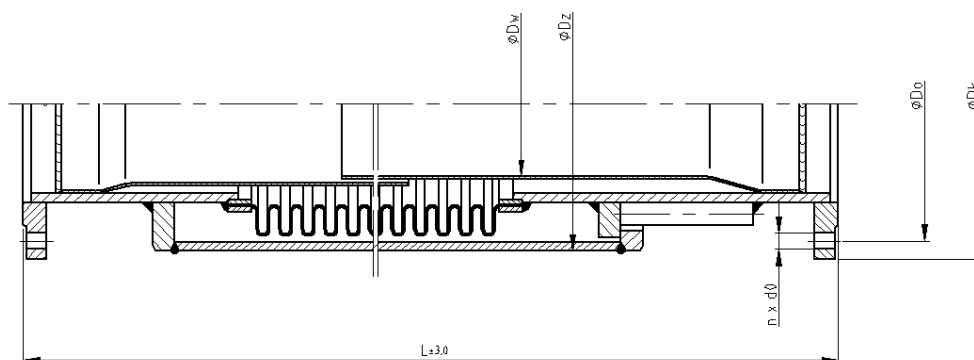

DN	PN	Oznaczenie	Kompensator				Kołnierz					Pow. czynna	Szywność	Ciśnienie	
			L		Kompensacja		Dz	Dk	D0	d0	n			pracy	próbne
			W stanie swob.	W stanie nap.	W stanie swob.	W stanie nap.									
80	6	KFP80-6ss						190	150		4	83	41	0,6	0,9
	10	KFP80-10ss	405	435	60=(±30)	-60	133,0	200	160	18	8		56	1,0	1,5
	16	KFP80-16ss						200	160				83	1,6	2,4
	25	KFP80-25ss	425	455				200	160	18	8		124	2,5	3,8
100	6	KFP100-6ss						210	170		4	139	110	0,6	0,9
	10	KFP100-10ss	450	485	70=(±35)	-70	168,3	220	180	18	8		166	1,0	1,5
	16	KFP100-16ss											1,6	2,4	
	25	KFP100-25ss	470	505				235	190	22	8		277	2,5	3,8
125	6	KFP125-6ss						240	200			200	120	0,6	0,9
	10	KFP125-10ss	465	500	70=(±35)	-70	219,1	250	210	18	8		176	1,0	1,5
	16	KFP125-16ss											1,6	2,4	
	25	KFP125-25ss	485	520				270	220	26	8		293	2,5	3,8
150	6	KFP150-6ss						265	225	18		273	130	0,6	0,9
	10	KFP150-10ss	470	505	70=(±35)	-70	244,5	285	240	22	8		195	1,0	1,5
	16	KFP150-16ss											1,6	2,4	
	25	KFP150-25ss	490	525				300	250	26	8		325	2,5	3,8
200	6	KFP200-6ss						320	280	18	8	458	100	0,6	0,9
	10	KFP200-10ss	485	520	70=(±35)	-70	298,5	340	295	22	8		147	1,0	1,5
	16	KFP200-16ss									12		1,6	2,4	
	25	KFP200-25ss	505	540				360	310	26	12		245	2,5	3,8
250	6	KFP250-6ss						375	335	18		693	105	0,6	0,9
	10	KFP250-10ss	495	530	70=(±35)	-70	355,6	395	350	22	12		155	1,0	1,5
	16	KFP250-16ss						405	355	26			1,6	2,4	
	25	KFP250-25ss	515	550				425	370	30	12		258	2,5	3,8
300	6	KFP300-6ss						440	395	22		962	113	0,6	0,9
	10	KFP300-10ss	510	545	70=(±35)	-70	406,4	445	400	26	12		170	1,0	1,5
	16	KFP300-16ss						460	410	26			1,6	2,4	
	25	KFP300-25ss	530	565				485	430	30	16		283	2,5	3,8
350	6	KFP350-6ss						490	445	22	12	1140	113	0,6	0,9
	10	KFP350-10ss	525	560	70=(±35)	-70	457,0	505	460	22	16		170	1,0	1,5
	16	KFP350-16ss						520	470	26			1,6	2,4	
	25	KFP350-25ss	545	580				555	490	33	16		283	2,5	3,8



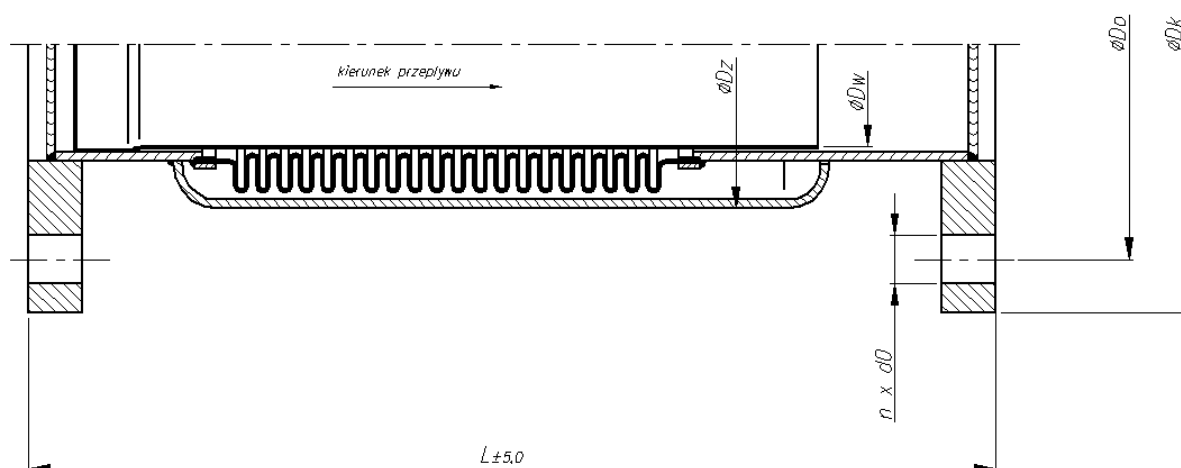

DN	PN	Oznaczenie	Kompensator				Kołnierz				Pow. czynna cm ²	Sztywność N/mm	Ciśnienie	
			L mm	Kompensacja mm	D _z mm	D _w mm	D _k mm	D _o mm	d _o mm	n			pracy MPa	próbne MPa
80	10	KFP80-10ss/60	300	60=(±30)	133,0	77,0	200	160	18	8	73,1	56,5	1,0	1,5
	16	KFP80-16ss/60			1,6	2,4								
100	10	KFP100-10ss/100	375	100=(±50)	159,0	95,0	220	180	18	8	112,2	28,6	1,0	1,5
	16	KFP100-16ss/100			1,6	2,4								
125	10	KFP125-10ss/100	390	100=(±50)	193,7	120,0	250	210	18	8	165,1	32,7	1,0	1,5
	16	KFP125-16ss/100			1,6	2,4								
150	10	KFP150-10ss/100	390	100=(±50)	219,1	145,0	285	240	22	8	227,0	38,4	1,0	1,5
	16	KFP150-16ss/100			1,6	2,4								
200	10	KFP200-10ss/100	400	100=(±50)	273,0	201,5	340	295	22	8	406,5	60,6	1,0	1,5
	16	KFP200-16ss/100			1,6	2,4								



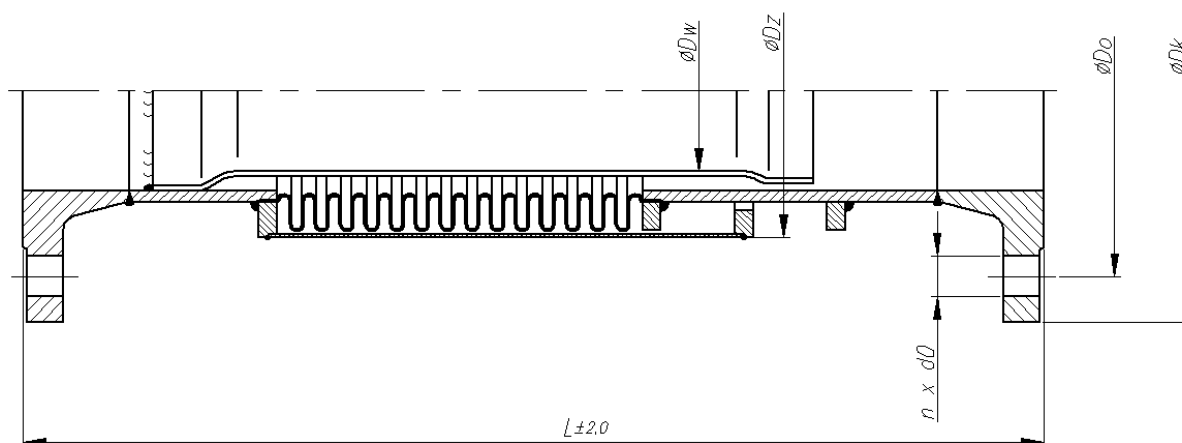

DN	PN	Oznaczenie	Kompensator				Kołnierz			Pow. czynna cm ²	Sztwność ±50% N/mm	Ciśnienie		
			L mm	Dw mm	Dz mm	Kompensacja mm	Dk mm	Do mm	Nxd0 mm			pracy MPa	próbne MPa	
20	6	KF20-6s	230	19,5	36,5	16=(±8)	90	65	4x11	5,7	16	0,6	0,9	
	10	KF20-10s	245				105	75	4x14			1,0	1,5	
	16	KF20-16s							23			1,6	2,4	
25	6	KF25-6s	254	25,0	44,5	22=(±11)	100	75	4x11	9,2	12	0,6	0,9	
	10	KF25-10s	260				115	85	4x14			1,0	1,5	
	16	KF25-16s							17			1,6	2,4	
32	6	KF32-6s	294	32,0	57,0	50=(±25)	120	90	4x14	16,0	12	0,6	0,9	
	10	KF32-10s	304				140	100	4x18			16	1,0	1,5
	16	KF32-16s							24			1,6	2,4	
40	6	KF40-6s	300	40,0	64,0	50=(±25)	130	100	4x14	21,0	12	0,6	0,9	
	10	KF40-10s	308				150	110	4x18			16	1,0	1,5
	16	KF40-16s							23			1,6	2,4	
50	6	KF50-6s	300	50,0	80,0	50=(±25)	140	110	4x14	34,0	52	0,6	0,9	
	10	KF50-10s	314				165	125	4x18			1,0	1,5	
	16	KF50-16s							68			1,6	2,4	
	25	KF50-25s	333				165	125	4x18			34,0	125	2,5
65	6	KF65-6s	300	65,0	93,0	50=(±25)	160	130	4x14	48,0	45	0,6	0,9	
	10	KF65-10s	314				185	145	4x18			1,0	1,5	
	16	KF65-16s										64	1,6	2,4
	25	KF65-25s	345									8x18	62	2,5



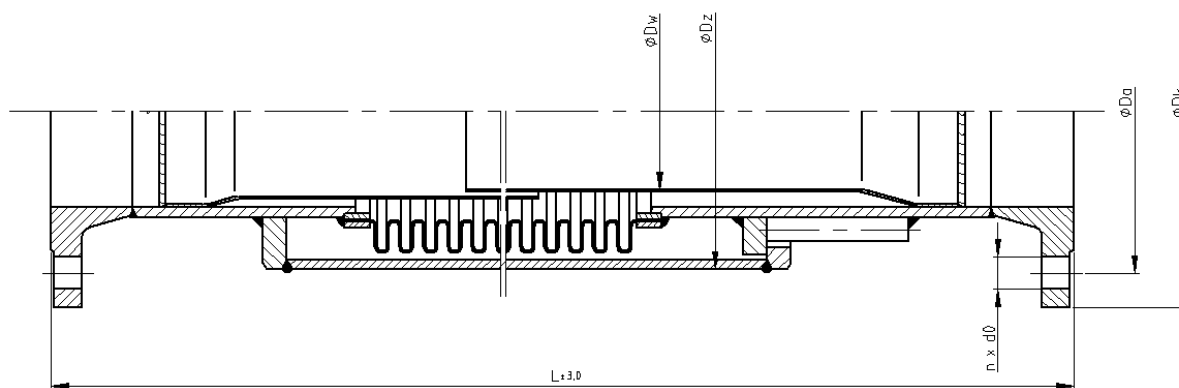

DN	PN	Oznaczenie	Kompensator					Kołnierz			Pow. czynna cm ²	Sztynność N/mm	Ciśnienie		
			L		Dw	Kompensacja		Dz	Dk	Do			nxdo	pracy	próbne
			W stanie swob.	W stanie nap.		W stanie swob.	W stanie nap.								
80	6	KF80-6ss	450	480	65,0	60=(±30)	-60	133,0	190	150	4x18	83	41	0,6	0,9
	10	KF80-10ss	466	496					56	1,0	1,5				
	16	KF80-16ss	466	496					83	1,6	2,4				
	25	KF80-25ss	502	532					124	2,5	3,8				
100	6	KF100-6ss	491	526	82,0	70=(±35)	-70	168,3	210	170	4x18	139	110	0,6	0,9
	10	KF100-10ss	505	540					110	1,0	1,5				
	16	KF100-16ss	505	540					160	1,6	2,4				
	25	KF100-25ss	551	586					277	2,5	3,8				
125	6	KF125-6ss	502	537	107,0	70=(±35)	-70	219,1	240	200	8x18	200	120	0,6	0,9
	10	KF125-10ss	516	551					120	1,0	1,5				
	16	KF125-16ss	516	551					176	1,6	2,4				
	25	KF125-25ss	562	597					293	2,5	3,8				
150	6	KF150-6ss	502	537	127,0	70=(±35)	-70	244,5	265	225	8x18	273	130	0,6	0,9
	10	KF150-10ss	516	551					130	1,0	1,5				
	16	KF150-16ss	516	551					195	1,6	2,4				
	25	KF150-25ss	576	611					325	2,5	3,8				
200	6	KF200-6ss	526	561	186,6	70=(±35)	-70	298,5	320	280	8x18	458	100	0,6	0,9
	10	KF200-10ss	540	575					100	1,0	1,5				
	16	KF200-16ss	540	575					147	1,6	2,4				
	25	KF200-25ss	596	631					245	2,5	3,8				
250	6	KF250-6ss	536	571	240,0	70=(±35)	-70	355,6	375	335	12x18	693	105	0,6	0,9
	10	KF250-10ss	552	587					105	1,0	1,5				
	16	KF250-16ss	556	591					155	1,6	2,4				
	25	KF250-25ss	612	647					258	2,5	3,8				
300	6	KF300-6ss	550	585	284,0	70=(±35)	-70	406,4	440	395	12x22	962	113	0,6	0,9
	10	KF300-10ss	562	597					113	1,0	1,5				
	16	KF300-16ss	582	617					170	1,6	2,4				
	25	KF300-25ss	630	665					283	2,5	3,8				
350	6	KF350-6ss	550	585	314,0	70=(±35)	-70	457,0	490	445	12x22	1140	113	0,6	0,9
	10	KF350-10ss	562	597					113	1,0	1,5				
	16	KF350-16ss	590	625					170	1,6	2,4				
	25	KF350-25ss	646	681					283	2,5	3,8				



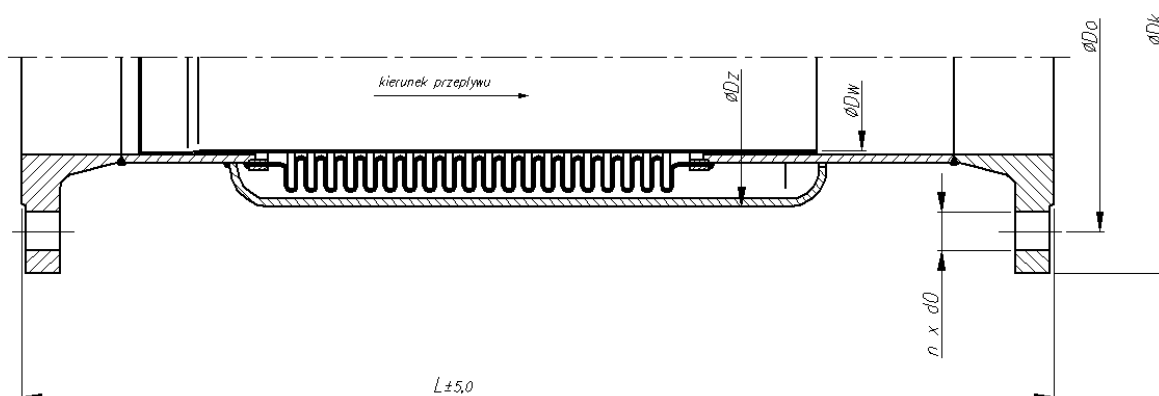

DN	PN	Oznaczenie	Kompensator				Kołnierz				Pow. czynna cm ²	Sztywność N/mm	Ciśnienie	
			L	Dw	Dz	Kompensacja	Dk	D _o	d _o	n			pracy	próbne
			mm	Mm	mm	mm	mm	mm	mm				MPa	MPa
80	10	KF80-10ss/60	380	77,0	133,0	60=(±30)	200	160	18	8	73,1	56,5	1,0	1,5
	16	KF80-16ss/60											1,6	2,4
100	10	KF100-10ss/100	460	95,0	159,0	100=(±50)	220	180	18	8	112,2	28,6	1,0	1,5
	16	KF100-16ss/100											1,6	2,4
125	10	KF125-10ss/100	480	120,	193,7	100=(±50)	250	210	18	8	165,1	32,7	1,0	1,5
	16	KF125-16ss/100											1,6	2,4
150	10	KF150-10ss/100	480	145,0	219,1	100=(±50)	285	240	22	8	227,0	38,4	1,0	1,5
	16	KF150-16ss/100											1,6	2,4
200	10	KF200-10ss/100	505	201,5	273,0	100=(±50)	340	295	22	8	406,5	60,6	1,0	1,5
	16	KF200-16ss/100											1,6	2,4

